

ILLUMINATED SWITCH
ML9 SERIES

Tact Switch
Illuminated

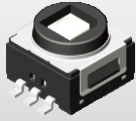

NEW



ML9

FEATURES

- ※ Various LED options
- ※ 300,000 operation life cycles

APPLICATION

- ※ Automotive
- ※ Network equipment
- ※ Telecommunications
- ※ Medical equipment
- ※ Industrial controls

SPECIFICATION

Contact Rating	50mA, 32V DC
Contact Resistance	100mΩ max.
Insulation Resistance	100MΩ min. 100V DC
Dielectric Strength	250V AC/1 minute
Operating Force	400±100gf
Travel	0.45mm
Operating Life	300, 000 cycles
Operating Temp.	-40°C ~ +85°C
Storage Temp.	-55°C ~ +85°C

HOW TO ORDER

ML9 - M **QR**

- S.M.T.
- =Without Post
- P=With Post
- Operation Force:
4=400gf
- Package:
Tape & Reel
- Halogen Free
- LED Color:
=Without LED
- B=Blue
- G=Green
- R=Red
- W=White
- O=Orange

CIRCUIT

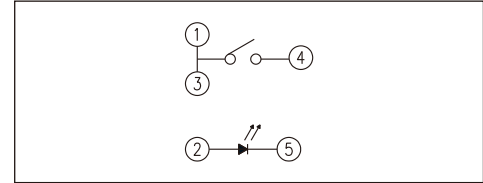

PACKAGE

<Tape & Reel>
To be confirmed

ML9

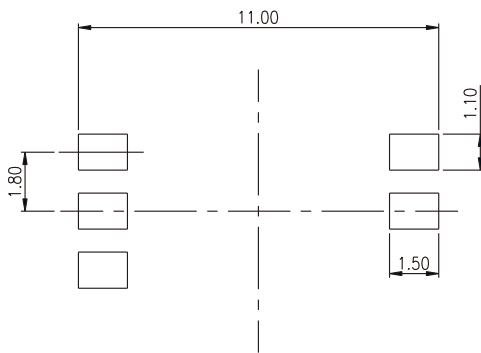
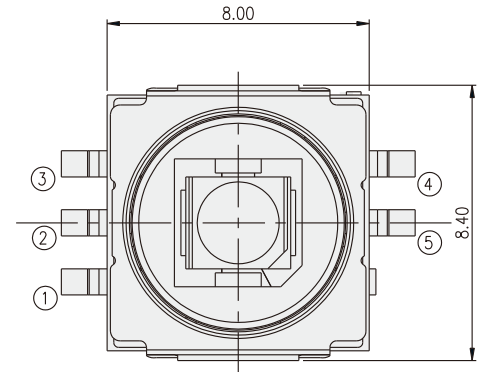
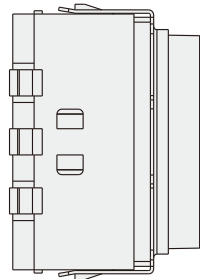
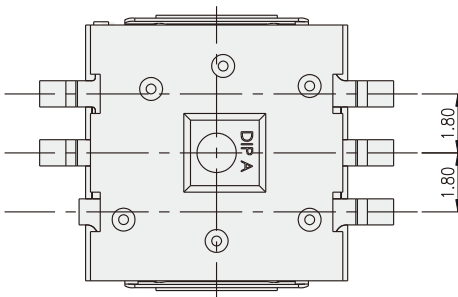

P.C.B. LAYOUT

