

**FEATURES**

- ※2.0mm height
- ※1P2T model
- ※Stroke 2.7mm

**APPLICATION**

- ※Remote control
- ※Consumer electronics
- ※Instrumentations

**SPECIFICATION**

Contact Rating	0.3A, 4V DC
Contact Resistance	70mΩ max.
Insulation Resistance	100MΩ min. 100V DC
Dielectric Strength	100V AC/1 minute
Operating Force	180±70gf
Travel	2.7mm
Operating Life	10,000 cycles
Operating Temp.	-10°C ~ +60°C
Storage Temp.	-20°C ~ +75°C

**HOW TO ORDER**

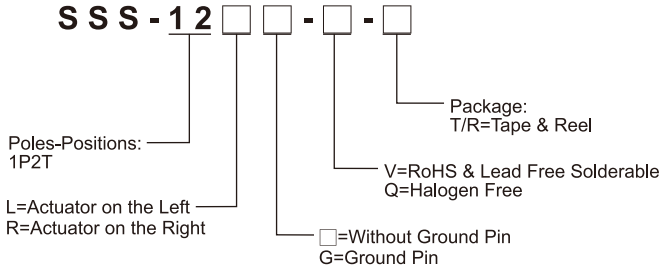

**CIRCUIT**

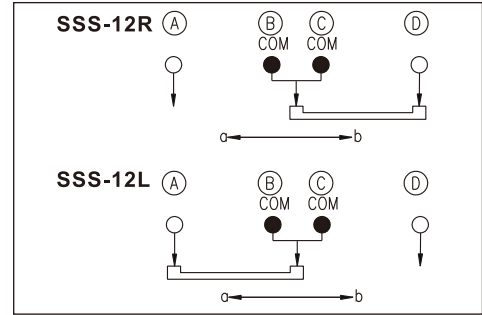

**PACKAGE**

<Tape & Reel>  
2000 pcs

**SSS-12R**

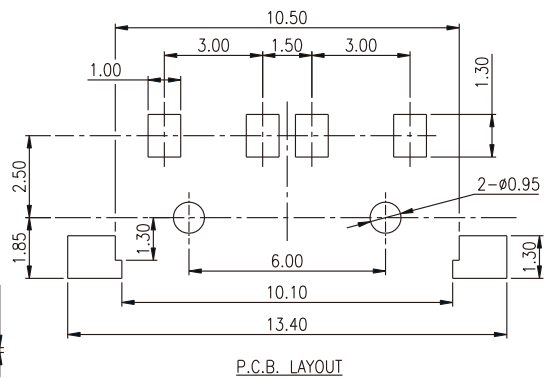
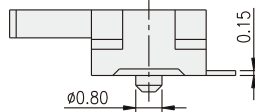
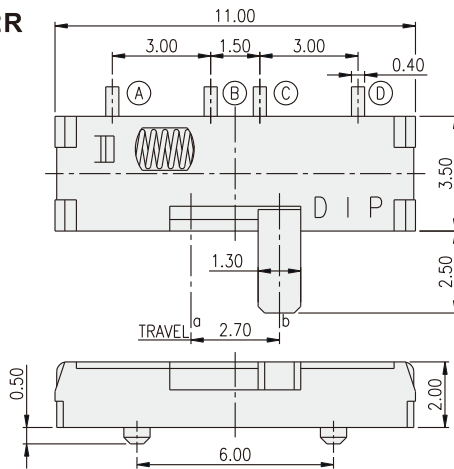

**SSS-12LG**

