

TACT SWITCH TM/TJ()-5 SERIES

5x5 SMT & J SMT Type
(H: 0.8 & 1.5mm)

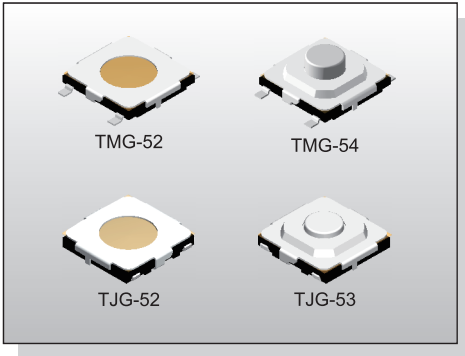

FEATURES

- ✘ Compact-sized 5x5mm
- ✘ Available from 0.8mm-3.0mm height
- ✘ With ground terminal

APPLICATION

- ✘ Smart Phone
- ✘ Digital Camera, Medical
- ✘ Portable Electronic Device

SPECIFICATION

Contact Rating	50mA, 12V DC
Contact Resistance	100mΩ max.
Insulation Resistance	100MΩ min. 500V DC
Dielectric Strength	250V AC/1 minute
Operating Force	70±30gf/ 100±50gf/160±50gf 260±50gf
Travel	0.25+0.1/-0.2mm
Operating Life	200,000 cycles for 260gf 1,000,000 cycles for 160/100/70gf
Operating Temp.	-25°C ~ +70°C
Storage Temp.	-30°C ~ +80°C

HOW TO ORDER

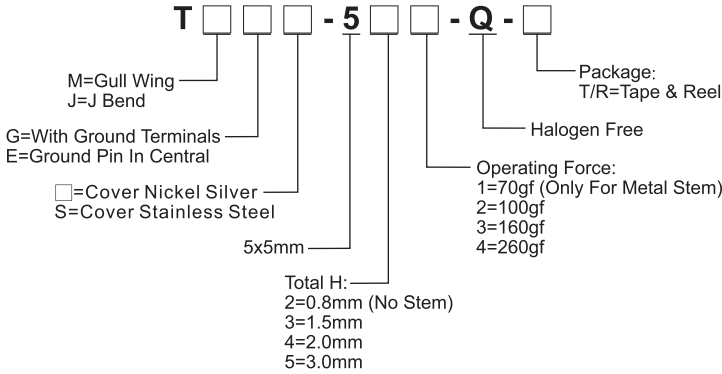

CIRCUIT

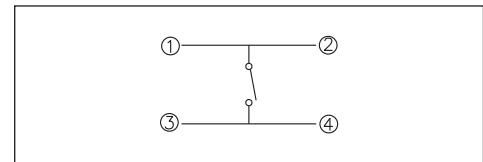

PACKAGE

<Tape & Reel>
4000 pcs

TACT SWITCH

TME-5

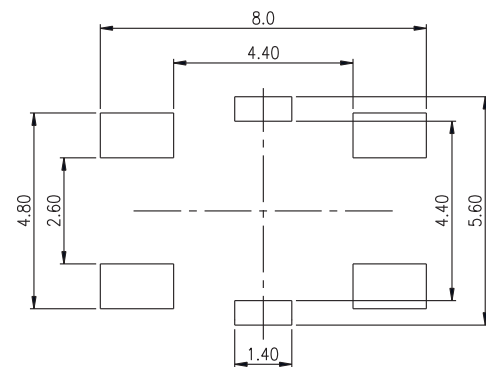
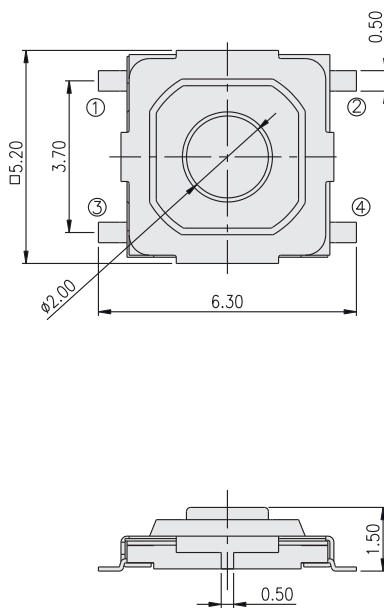

P.C.B. LAYOUT

TACT SWITCH
TM/TJ()-5 SERIES

5x5 SMT & J SMT Type
 (H: 0.8 & 1.5mm)



TMG-53

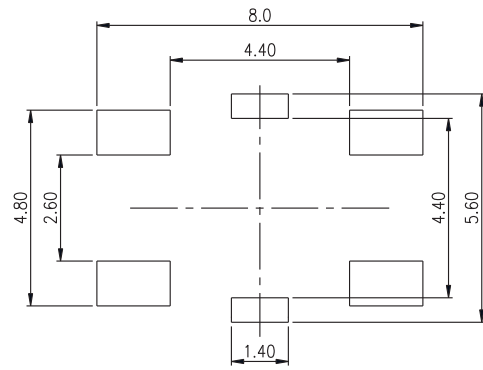
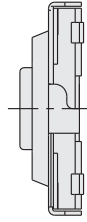
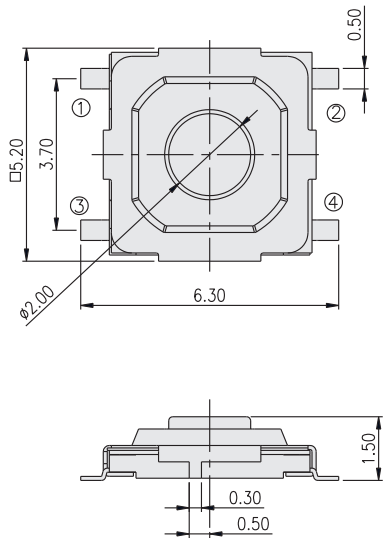

P.C.B. LAYOUT

TACT SWITCH

TMG-52

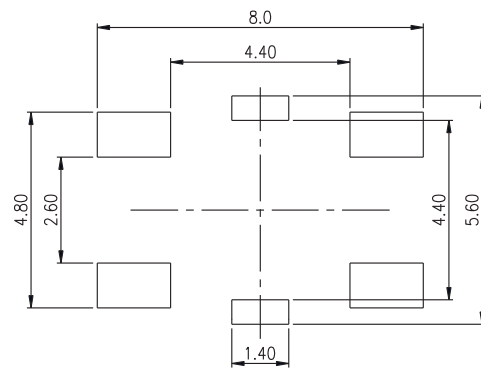
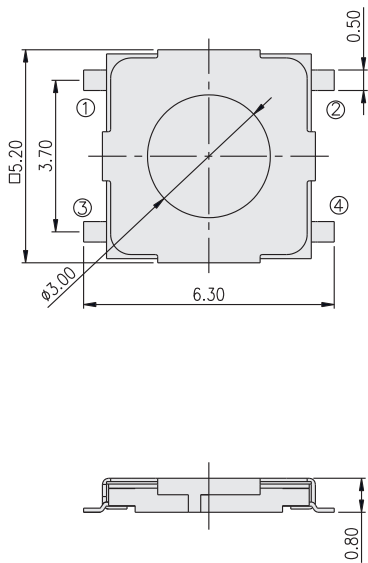

P.C.B. LAYOUT

TACT SWITCH
TM/TJ()-5 SERIES

5x5 SMT & J SMT Type
 (H: 0.8 & 1.5mm)



TJG-53

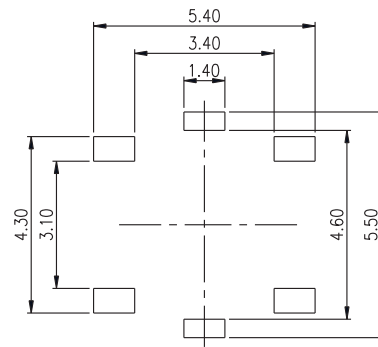
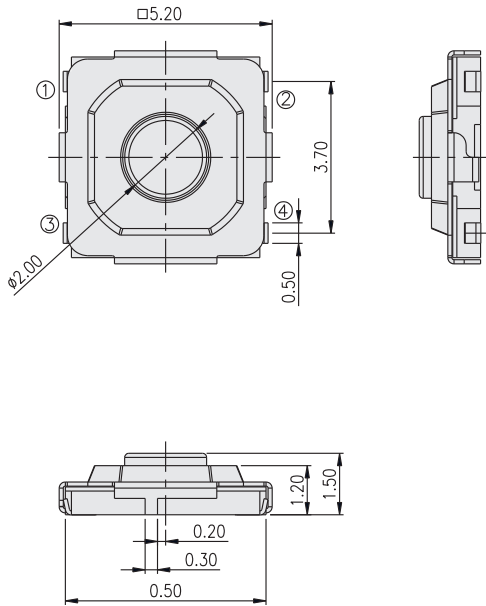

P.C.B. LAYOUT

TACT SWITCH

TJG-52

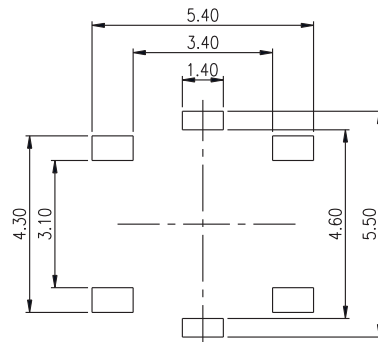
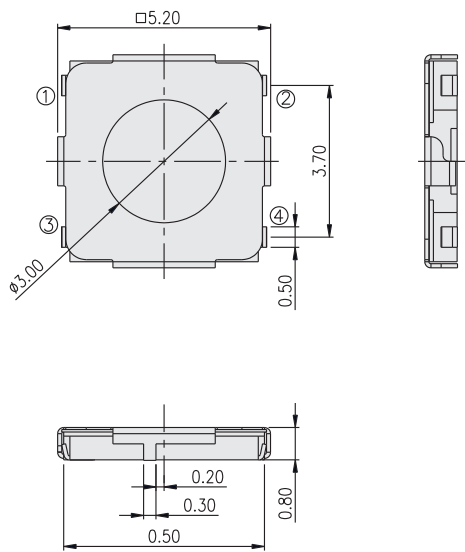

P.C.B. LAYOUT