

FEATURES

- ※ Compact-sized 5.2x5.2mm
- ※ Long operating life
- ※ With ground terminal

APPLICATION

- ※ Smart phone
- ※ Digital camera, Medical
- ※ Portable electronic device

SPECIFICATION

Contact Rating	50mA, 12V DC
Contact Resistance	100mΩ max.
Insulation Resistance	100MΩ min. 500V DC
Dielectric Strength	250V AC/1 minute
Operating Force	70±50gf/ 100±50gf/160±50gf 260±50gf
Travel	0.25mm
Operating Life	200,000 cycles for 260gf 1,000,000 cycles for 160/100/70gf
Operating Temp.	-25°C ~ +70°C
Storage Temp.	-30°C ~ +80°C

HOW TO ORDER

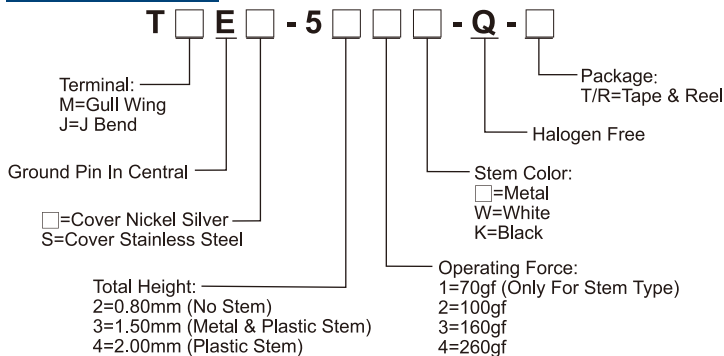

CIRCUIT

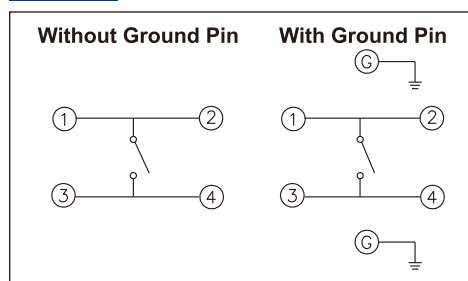

PACKAGE

<Tape & Reel>
 T□E-52, 53=4000 pcs
 T□E-54=3000 pcs

TACT SWITCH

TME-5

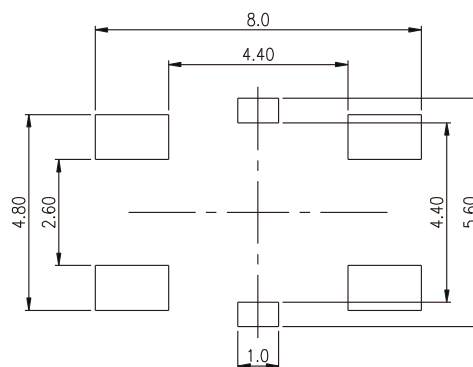
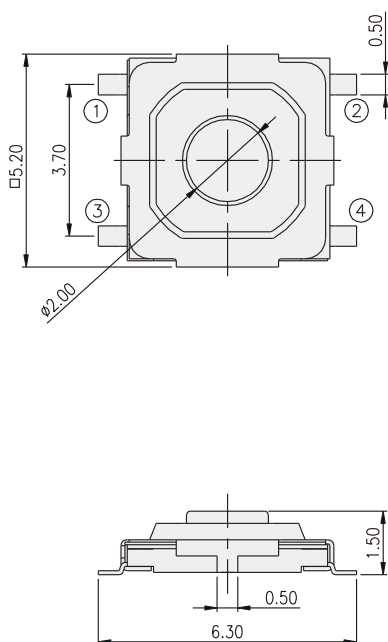

P.C.B. LAYOUT

TJE-53

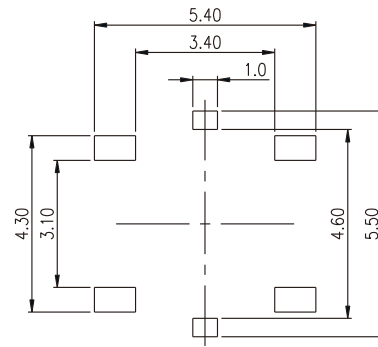
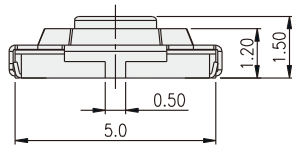
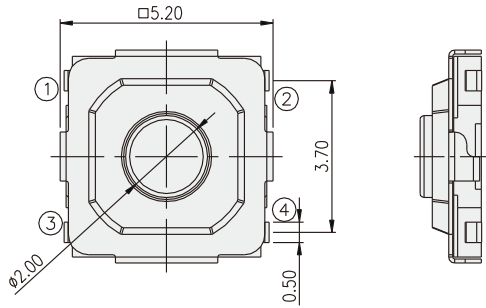

P.C.B. LAYOUT

TACT SWITCH

TME-52

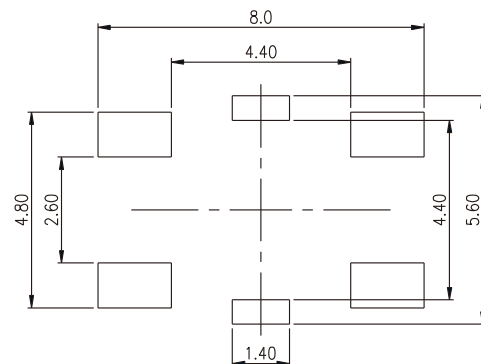
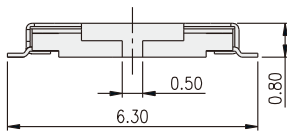
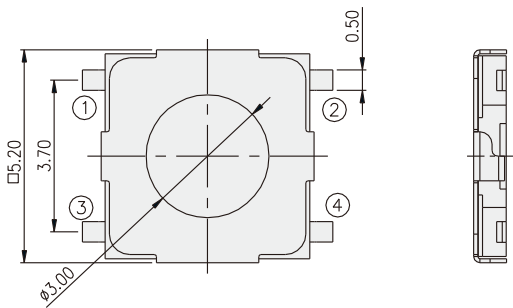

P.C.B. LAYOUT